

JUKI®

Semi-dry-head, High-speed, Overlock / Safety Stitch Machine

MO-6700D Series

Semi-dry-head



MO-6714D

MO-6700D Series

JUKI's dry-head technology eliminates oil stains on the sewing product.

MO-6100D Series is the world's first complete dry-head overlock machine.

This cutting-edge dry-head technology has been introduced to the MO-6700S, which has an established reputation for its excellent seam quality and higher productivity. Only the parts which mainly contribute to oil splashes are improved to have dry mechanisms. This reduces cost and makes a practical dry-head machine, the MO-6700D Series.



Oil stains on the sewing product are eliminated.

- Oil splashes are substantially reduced to eliminate oil stains on sewing products, thereby upgrading the finished quality.
- The frequency of stain removal or re-sewing is reduced.
- The machine achieves a practical maximum sewing speed of 6,000rpm.

Cutting-edge dry technology for achieving a lubrication-free mechanism.

- The needle bar mechanism and upper looper mechanism have been re-designed to require no lubrication.
- The most-advanced dry technologies, such as the special surface treatment applied to the major drive unit and the grease feeding method, contribute to higher durability. The machine does not splash oil after a long-period of use.

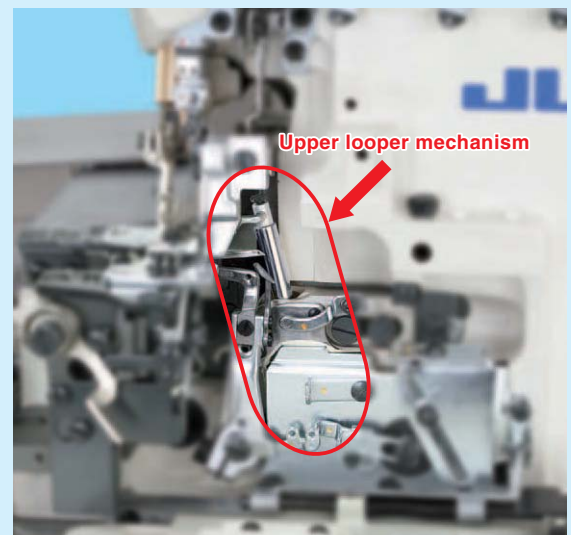
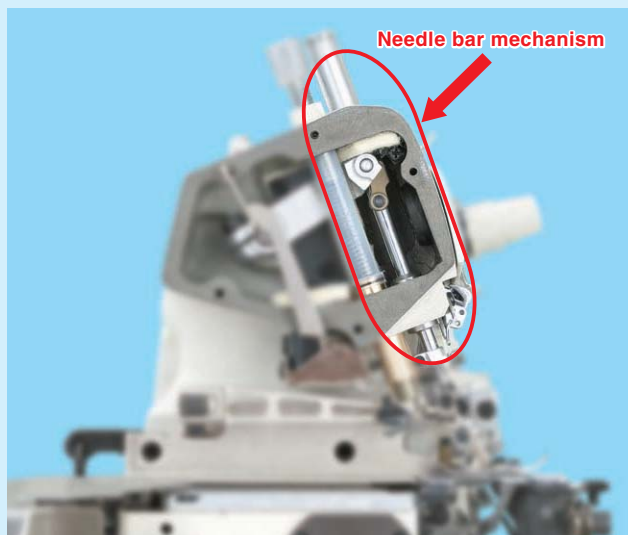

SUBCLASS MACHINE LIST

A variety of subclass machines is available.

Seams	Model No.	Materials L ▶ H	Number of needles	Number of threads	Needle gauge (mm)	Overredging width (mm)	Number of feed dog rows	Stitch length (mm)	Bottom differential-feed ratio	Presser lifting amount (mm)	Needle system	Max. sewing speed (rpm)	Remarks
-------	-----------	--------------------	-------------------	-------------------	-------------------	------------------------	-------------------------	--------------------	--------------------------------	-----------------------------	---------------	-------------------------	---------

<1-needle overlock>

● For runstitching in general fabric

	MO-6704D-0E4-300	L~M	1	3	—	4.0	2	4	1:0.7~1:2	7	DCX27 #11	6,000	Upper looper high throw type
	MO-6704D-0E4-307		1	3	—	4.0	2	4	1:0.7~1:2	7	DCX27 #11	6,000	
	MO-6704D-0F4-307		1	3	—	4.8	2	4	1:0.7~1:2	7	DCX27 #11	6,000	
	MO-6704D-0E4-40H	M~H	1	3	—	4.0	2	4	1:0.7~1:2	7	DCX27 #11	6,000	Upper looper extra high throw type
	MO-6704D-0F6-50H		1	3	—	4.8	3	4	1:0.7~1:2	7	DCX27 #14	6,000	

● For blind hemming ★L121: Blind stitch hemming attachment

	MO-6705D-0D4-210/L121	L~M	1	3	—	3.2	2	4	1:0.7~1:2	5.5	DCX27 #9	6,000	
--	-----------------------	-----	---	---	---	-----	---	---	-----------	-----	----------	-------	--

● For rolled hemming (folded downward)

	MO-6704D-0A4-150	EL~L	1	3	—	1.6	2	4	1:0.7~1:2	5	DCX1 #8	6,000	
	MO-6704D-0A5-150		1	3	—	1.6	1	4	1:0.7~1:2	5	DCX1 #8	6,000	

<2-needle overlock>

● For runstitching in general fabric

	MO-6714D-BE6-307	L~M	2	4	2.0	4.0	3	4	1:0.7~1:2	6.5	DCX27 #11	6,000	Upper looper high throw type
	MO-6714D-BE6-40H	M~H	2	4	2.0	4.0	3	4	1:0.7~1:2	6.5	DCX27 #11	6,000	Upper looper extra high throw type
	MO-6712D-DF6-50F		2	4	3.2	4.8	3	4	1:0.7~1:2	6.5	DCX27 #14	6,000	
	MO-6714D-BB6-30P	L~M	2	4	2.0	2.0	3	4	1:0.7~1:2	6.5	DCX27 #11	6,000	Anti-material-slip
	MO-6714D-BD6-30P		2	4	2.0	3.2	3	4	1:0.7~1:2	6.5	DCX27 #11	6,000	
	MO-6714D-BE6-30P		2	4	2.0	4.0	3	4	1:0.7~1:2	6.5	DCX27 #11	6,000	

● For gathering ★S162: Swing-type gathering device (manual-lever operated)

	MO-6714D-BE6-327/S162	L~M	2	4	2.0	4.0	3	3.2	1:0.9~1:2.6	6	DCX27 #11	6,000	Upper looper high throw type
--	-----------------------	-----	---	---	-----	-----	---	-----	-------------	---	-----------	-------	------------------------------

● For tape attaching ★G39: Tape attaching presser foot ★Q141: Tape guide

	MO-6714D-BD6-347/G39/Q141	M~H	2	4	2.0	3.2	3	3.2	1:0.9~1:2.6	7	DCX27 #11	6,000	Upper looper high throw type
	MO-6714D-BE6-347/G39/Q141		2	4	2.0	4.0	3	3.2	1:0.9~1:2.6	7	DCX27 #11	6,000	
	MO-6714D-BD6-34H/G39/Q141		2	4	2.0	3.2	3	3.2	1:0.9~1:2.6	7	DCX27 #11	6,000	Upper looper extra high throw type
	MO-6714D-BE6-34H/G39/Q141		2	4	2.0	4.0	3	3.2	1:0.9~1:2.6	7	DCX27 #11	6,000	
	MO-6714D-BE6-44H/G39/Q141		2	4	2.0	4.0	3	3.2	1:0.9~1:2.6	7	DCX27 #14	6,000	



● Blind hemming
MO-6705D-0D4-210/L121
(L121: Blind stitch hemming attachment)



● Gathering
MO-6714D-BE6-327/S162
(S162: Swing-type gathering device, manual-lever operated)



● Rolling in tape
MO-6745D-FF4-360/N077
(N077: Clean finish top and bottom)

Seams	Model No.	Materials	Number of needles	Number of threads	Needle gauge (mm)	Overredging width (mm)	Number of feed dog rows	Stitch length (mm)	Bottom differential-feed ratio	Presser lifting amount (mm)	Needle system	Max. sewing speed (rpm)	Remarks
-------	-----------	-----------	-------------------	-------------------	-------------------	------------------------	-------------------------	--------------------	--------------------------------	-----------------------------	---------------	-------------------------	---------

<Safety stitching>

● For runstitching in general fabric ★E35: Latch for changing overredging width

	MO-6716D-DE4-300	L~M	2	5	3.2	4.0	2	4	1:0.7~1:2	7	DCX27 #11	6,000	Upper looper high throw type
	MO-6716D-DE6-307		2	5	3.2	4.0	3	4	1:0.7~1:2	7	DCX27 #11	6,000	
	MO-6716D-DF4-307		2	5	3.2	4.8	2	4	1:0.7~1:2	7	DCX27 #11	6,000	
	MO-6716D-DE4-40H	M~H	2	5	3.2	4.0	2	4	1:0.7~1:2	7	DCX27 #11	6,000	Upper looper extra high throw type
	MO-6716D-DE4-40H/E35		2	5	3.2	4.0	2	4	1:0.7~1:2	7	DCX27 #11	6,000	
	MO-6716D-DE6-40H		2	5	3.2	4.0	3	4	1:0.7~1:2	7	DCX27 #11	6,000	Upper looper high throw type
	MO-6716D-FF6-307		2	5	4.8	4.8	3	4	1:0.7~1:2	7	DCX27 #11	6,000	
	MO-6716D-FF6-40H		2	5	4.8	4.8	3	4	1:0.7~1:2	7	DCX27 #11	6,000	
	MO-6716D-FF6-50H		2	5	4.8	4.8	3	4	1:0.7~1:2	6.5	DCX27 #16	6,000	
	MO-6716D-FH6-50H	2	5	4.8	6.4	3	4	1:0.7~1:2	6.5	DCX27 #16	6,000	Upper looper extra high throw type	
	MO-6716D-DE4-30P	L~M	2	5	3.2	4.0	2	4	1:0.7~1:2	7	DCX27 #11		6,000
	MO-6716D-FF4-30P		2	5	4.8	4.8	2	4	1:0.7~1:2	7	DCX27 #11	6,000	Anti-material-slip

● For gathering ★S159: Swing-type gathering device (interlocked with pedal)

	MO-6716D-FF6-42H/S159	M~H	2	5	4.8	4.8	3	3.2	1:0.9~1:2.6	6	DCX27 #14	6,000	Upper looper extra high throw type
---	-----------------------	-----	---	---	-----	-----	---	-----	-------------	---	-----------	-------	------------------------------------

● For rolling-in tape ★N077: Clean finish top and bottom

	MO-6745D-FF4-360/N077	L~M	2	4	4.8	4.8	2	4	1:0.7~1:2	5	DCX27 #11	6,000	2-needle type for double-chainstitch on pocket bags
--	-----------------------	-----	---	---	-----	-----	---	---	-----------	---	-----------	-------	---

● 3-needle safety stitching

	MO-6743D-1D6-40H	M~H	3	6	4.8+2.0	3.2	3	4	1:0.7~1:2	6.5	DCX27 #11	6,000	Upper looper extra high throw type
	MO-6743D-2D6-40H		3	6	3.2+2.0	3.2	3	4	1:0.7~1:2	6.5	DCX27 #11	6,000	

Anti-material-slip type

MO-6714D-□□□-30P
MO-6716D-□□□-30P

The sewing machine is fully equipped with adjusting devices and provisions to effectively prevent puckering of difficult-to-sew materials or new-generation materials. The operator is able to produce beautifully finished high-quality seams without conducting difficult adjustments.

- The locus of feed and feed timing are selected to offer optimum conditions for sewing light-weight materials.
- The machine comes as standard with a low-pressure presser foot that is exclusively designed for light-weight materials and is able to remarkably handle small curves of the material. The presser foot helps the operator control lighter-weight material smoothly on the machine.

- The feed mechanism feeds double chainstitch looper thread with consistency, even under a low tension. (Safety stitch machine)



MO-6700D Series

DEVICES AND ATTACHMENTS

*Existing devices, attachments and gauges for the conventional MO-6000 Series are applicable to the MO-6700D Series.

Model	Part No.	Description
● Chain-off thread trimming device		
T039	MAT-039001A0	One-touch type tape cutter and chain-off thread trimming device (electromagnetic type)
	MAT-039002A0	
T040	MAT-040001A0	For semi-sunken type
	MAT-040001AA	For fully-sunken type
T041S	MAT-041000A0A	Pneumatic flat cutter
T042S	MAT-042000A0	Pneumatic side cutter (for overlock machine)

● Pneumatic chain-off thread suction device

MC-4	—	Specific to chain-off thread, pedal-operated
MC-5	—	Specific to chain-off thread
MC-8	—	Pneumatic chain-off thread + cloth chips
MC-9	—	Function of MC-8 + auto-lifter
MC-24	—	Pneumatic chain-off thread + cloth chips

*The aforementioned devices are not equipped with air regulator.
Please purchase the following components when you need to regulate air pressure.

—	PF-0552010-B0	Air regulator (F.R. unit asm.)
—	GMD-01080000X2	Fixing screw for F.R. unit asm.
—	F1021-003-000	Tube connector (male)
—	GAS-12063000*	One-touch connector *Selection parts instead of the tube connector

● Auto-lifter

AK32	GAK-320000A0	Pneumatic type (knee-operated)
AK49	GAK-490000A0	Pneumatic type (pedal-operated)
AK101	GAK-A01000A0	Pneumatic type (for servomotor)

Model	Part No.	Description	Feature
-------	----------	-------------	---------

● Gathering device

S159	MAS-159000A0	Swing-type gathering device (interlocked with pedal / for safety stitch machine)	The attachment opens with the presser foot pedal. This facilitates material setting on the machine. Furthermore, knee-control type differential-feed adjusting device is built in the attachment. It controls a differential-feed ratio as desired, thereby enabling the operator to make beautiful gathers.
S160	MAS-160000A0	Swing-type gathering device (interlocked with pedal / for overlock machine)	
S161	MAS-161000A0	Swing-type gathering device (manual-lever operated / for safety stitch machine)	The attachment is used to perform two different processes, joining fabric process and gathering process, at a time. The attachment can be opened/closed by using the lever (manually operated). The differential-feed ratio is controlled with the knee lever.
S162	MAS-162000A0	Swing-type gathering device (manual-lever operated / for overlock machine)	

● Blind hemming device

L121	MAL-121000A0	Blind stitch hemming attachment	A ruler used for blind hemming in knits
------	--------------	---------------------------------	---

● Piping folder

M056	MAM-0560J0A0	Piping folder	This piping folder makes a piping first, then turns up the tape.
M075	MAM-0750J0A0	Piping folder (to be used with knit tape)	This attachment can be used for both cotton bias tape with gimp and knit tape. The operation mode can be changed over with a fingertip control.
M076	MAM-0760N0A0	Ready-made piping folder	The dimension of ready-made tapes can be adjusted within the range of 8 to 13mm.

● Guide, Ruler

H153	MAH-153000A0	Cloth edge guide ruler (for overlock machine)	A swing type edge guide.
H154	MAH-154000A0	Cloth edge guide ruler (for safety stitch machine)	
Q141	MAQ-141000B0	Tape guide	This attachment is used attached on the machine head (face plate). It is used for tapes with the width of 7mm or less.

● Feller, Binder

K006	MAK-00601000	Upturn feller	This feller is exclusively used with the 3C0 throat plate. It is attached on the throat plate.
N067	MAN-0670D0A0	Reinforcement tape attachment binder (finished width: 4mm)	This binder binds the edge of a pocket bag while cutting round its periphery.
N077	MAN-0770E0A0	Clean finish top and bottom (finished width: 5mm)	This binder runstitches a pocket bag and binding its periphery with tape simultaneously.

● Miscellaneous

—	131-62557	Needle cooler unit asm.	For overlock machine	Needle cooler By silicon oil lubrication unit for the needle thread.
	SS-4091015SP	Screw		
	WP-0371026SD	Washer		
	SS-7110840SP	Screw		
	131-63159	Needle cooler unit asm.		
	SS-4091015SP	Screw		
WP-0371026SD	Washer			
—	131-63902	Presser	Needle thread heat remover By silicon oil lubricating unit for the needle thread.	
	131-63456	Silicon tank asm.		
	131-63803	Felt		
	TA-0950806R0	Rubber plug		
	SM-4040855SP	Screw		

[Reference]

Combination table of "chain-off thread suction device" and "auto-lifter" which correspond to "chain-off thread trimming device".

Chain-off thread trimming device	+	Chain-off thread suction device	Auto-lifter
T039		MC-8	AK101 (JUKI servomotor)
		MC-9	— (MC-9 is equipped with auto-lifter.)
T040		MC-5	AK32 (any motor will do)
		MC-24	AK32 (any motor will do)
T041S or T042S		MC-4	—
		MC-8	AK101 (JUKI servomotor)
		MC-9	— (MC-9 is equipped with auto-lifter.)

